

M&M INDUSTRIES, INC.

0.6 Gallon New Generation Pail



Prepared For: Standard Technical Specification
06/16/11 Revised: 3/13/17

General Specifications for cover:

Material:	High Density Polyethylene (HDPE)
Method of Mfg:	Injection Molding
Weight:	.166lbs. / 75g
Cover Height:	1.37"
Min. Wall Thickness:	.046" (46 mil)
Bottom OD:	7.03"
Gasket:	Neoprene / available without gasket
Case Qty:	180 per case / 1440 per pallet
Standard Color:	White, Red 186, Blue 300 Please inquire about custom colors

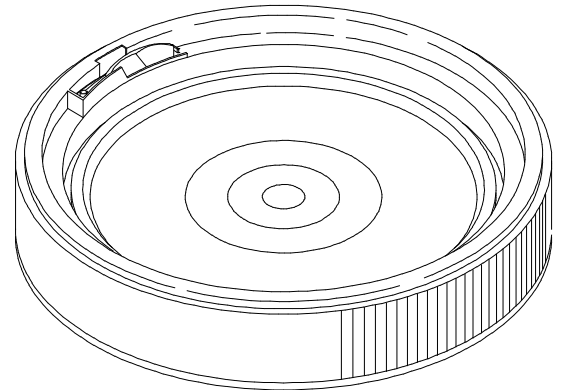

General Specifications for Pail:

Material:	High Density Polyethylene (HDPE)
Method of Mfg:	Injection Molding
Nominal Capacity:	0.6 Gallons
Weight:	.396lbs / 162g
Min. Wall Thickness:	.049" (49 mil)
Exterior Height:	6.88"
Top Inside Dia:	6.15"
Bottom Outside Dia:	5.60"
Shipping: Case:	40 pails and lids per case
Pallet:	780 units
Truckload:	28,080 units
Handle:	Plastic Handle
Printing Area:	3.75" x 18.25"
Nesting:	Tapered walls for nesting
Standard Color:	White Please inquire about custom colors
UN Certification:	1H2/Y4/S

Top ID: 6.15"

Height
6.88"

Height
w/cover
7.39"

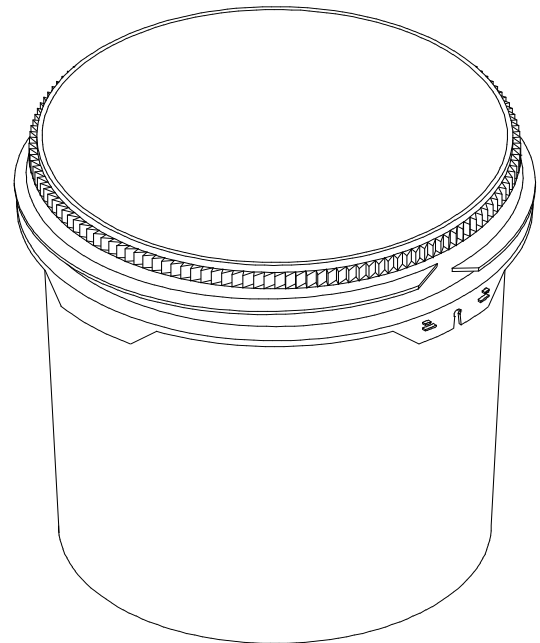

Bottom OD: 5.60"