

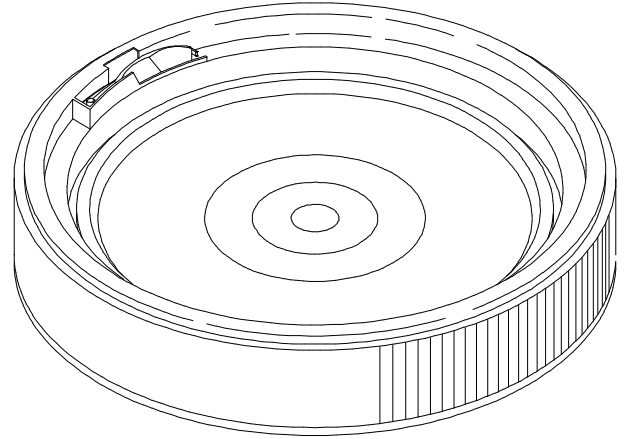

Prepared For: Standard Technical Specification
06/16/11 Revised: 3/14/17

General Specifications for cover:

Material:	High Density Polyethylene (HDPE)
Method of Mfg:	Injection Molding
Weight:	.321lbs/148g
Cover Height:	1.71"
Min. Wall Thickness:	.050" (50 mil)
Bottom OD:	8.90"
Gasket:	Neoprene
Case Qty:	90 per case / 720 per pallet
Standard Color:	White, Red 186, Blue300 Please inquire about custom colors



Top ID: 7.77"

General Specifications for Pail:

Material:	High Density Polyethylene (HDPE)
Method of Mfg:	Injection Molding
Nominal Capacity:	0.6 Gallons
Weight:	.69lbs/313g
Min. Wall Thickness:	.062" (62 mil)
Exterior Height:	8.54"
Top ID:	7.77"
Bottom OD:	7.06"
Shipping: Case:	20 pails and lids per case
Pallet:	400 units
Truckload:	14,400 units
Handle:	Plastic Handle
Printing Area:	5" x 22.75"
Nesting:	Tapered walls for nesting
Standard Color:	White Please inquire about custom colors
UN Certification:	1H2/Y6/S

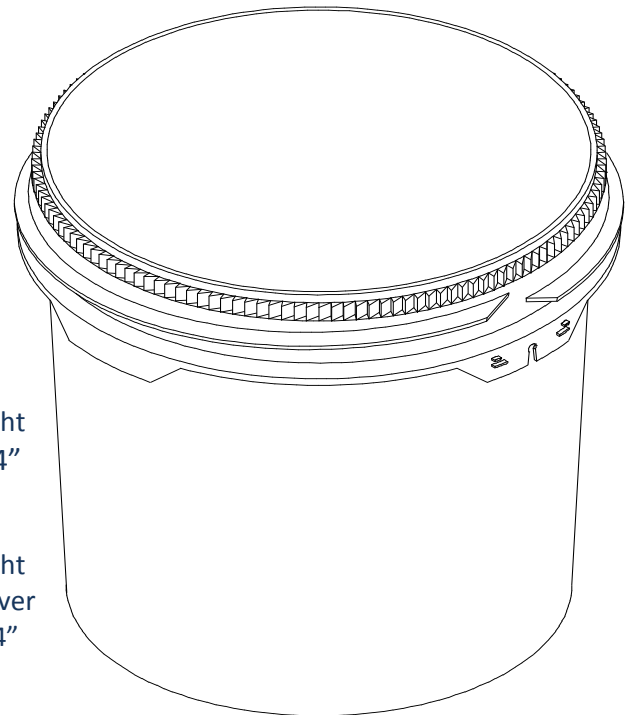

Height
8.54"

Height
w/cover
9.14"

Bottom OD: 7.06"