

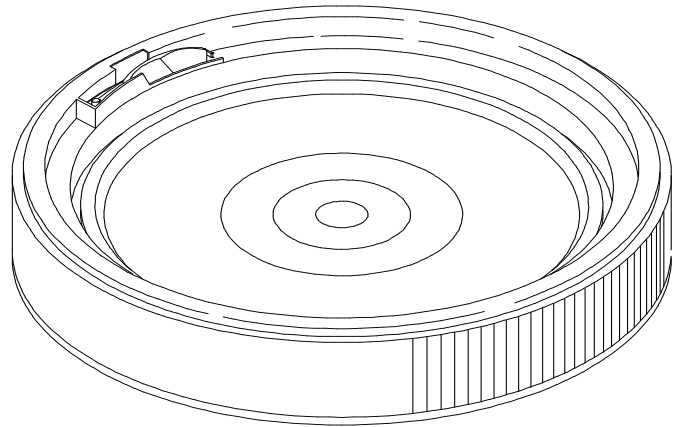

Prepared For: Standard Technical Specification 09/06/11  
Revised: 3/15/17

### General Specifications for cover:

**Material:** High Density Polyethylene (HDPE)  
**Method of Mfg:** Injection Molding  
**Weight:** 1.03lbs/470g  
**Cover Height:** 2.50"  
**Min. Wall Thickness:** .090" (90 mil)  
**Bottom OD:** 12.690"  
**Gasket:** Neoprene  
**Qty:** 240 per pallet  
**Standard Color:** White, Red186, Blue300  
Please inquire about custom colors



Top ID: 11.25 "

### General Specifications for Pail:

**Material:** High Density Polyethylene (HDPE)  
**Method of Mfg:** Injection Molding  
**Nominal Capacity:** 5.0 Gallons  
**Weight:** 2.36lbs/1071  
**Min. Wall Thickness:** .090" (90 mil)  
**Exterior Height:** 15.25"  
**Top ID:** 11.25"  
**Bottom OD:** 10.27 "  
**Shipping: Case:** 4 pails and lids per case      Height 15.25"  
**Pallet:** 120 units  
**Truckload:** 4,320 units  
**Handle:** Plastic Handle  
**Printing Dimensions:** 9.5" x 33"      Height w/cover 16.04"  
**Heat Transfer Dim:** 8.500" x 31.00"  
**Nesting:** Tapered walls for nesting  
**Standard Color:** White  
Please inquire about custom colors  
**UN Certification:** 1H2/Y30/S  
1H2/X11.5/S

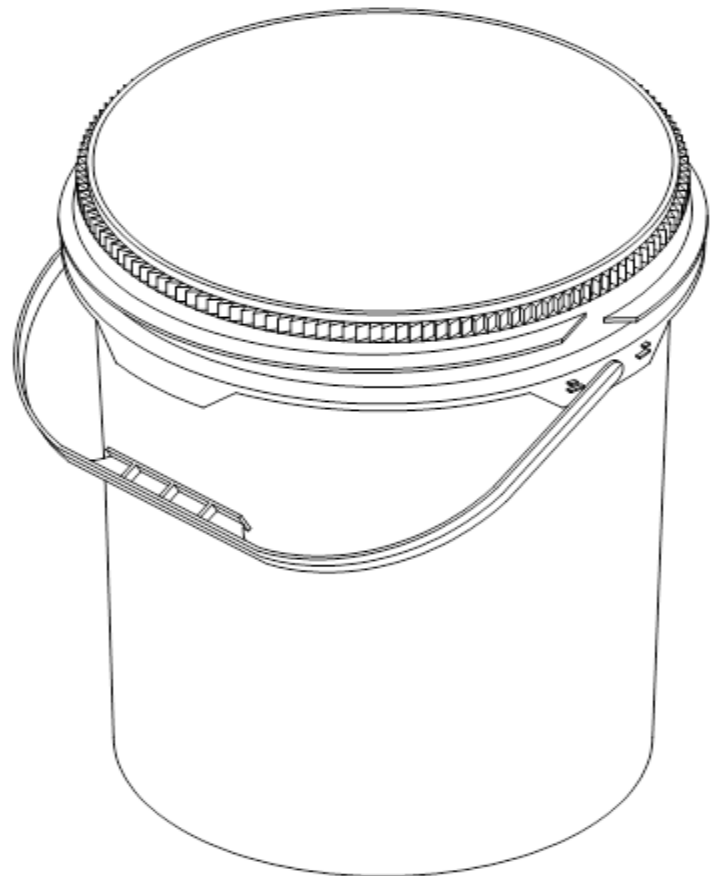

Bottom OD: 10.27"