

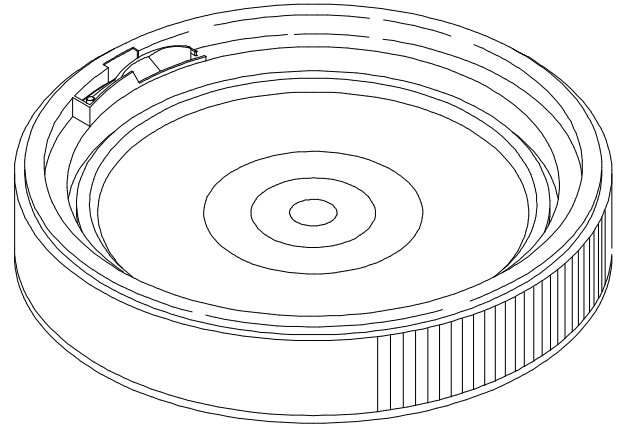

Prepared For: Standard Technical Specification
2/25/15 Revised: 4/16/15

General Specifications for cover:

Material:	High Density Polyethylene (HDPE)
Method of Mfg:	Injection Molding
Weight:	.75 lbs
Cover Height:	2.41"
Min. Wall Thickness:	.075" (75 mil)
Bottom OD:	11.72"
Gasket:	Neoprene
Qty:	240 per pallet
Standard Color:	White, Red186, Blue300 Please inquire about custom colors



Top ID: 10.100 "

General Specifications for Pail:

Material:	High Density Polyethylene (HDPE)
Method of Mfg:	Injection Molding
Nominal Capacity:	2.0 Gallons
Weight:	1.36 lbs
Min. Wall Thickness:	.090" (90 mil)
Exterior Height:	8.13"
Top ID:	10.100"
Bottom OD:	9.36 "
Shipping: Case:	8 pails and lids per case
Pallet:	168 units
Truckload:	5,208 units
Handle:	Plastic Handle
Printing Area:	4" x 29.75"
Nesting:	Tapered walls for nesting
Standard Color:	White Please inquire about custom colors
UN Certification:	1H2/Y15/S

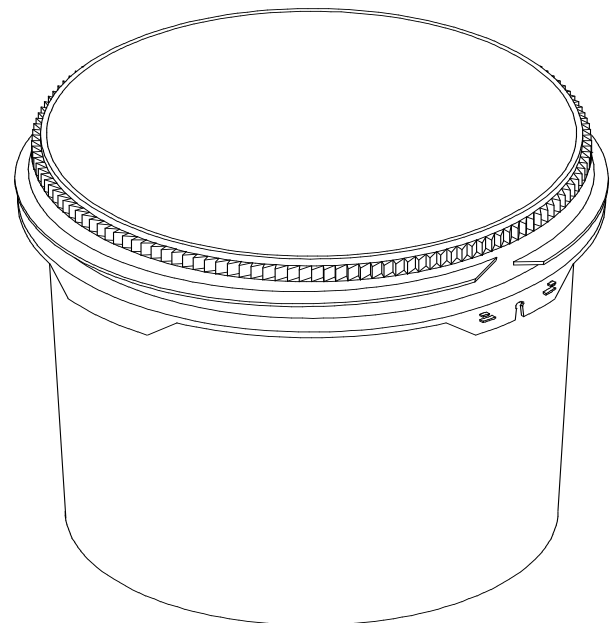

Height
8.13"

Height
w/cover
8.77"

Bottom OD: 9.36"